

FEMALE WELDING ELBOW

Type: 2071...3

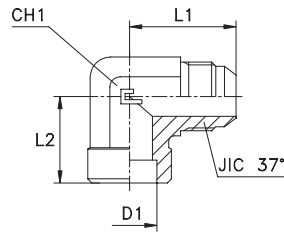

Series JIC	20.... [bar]	21.... [bar]	Ordering Complete	Ø Tube M	Ø Tube W	D1	L1	L2	CH1	JIC 37°
UNIVERSAL	450	450	207101.3	6	1/4	6	23	10	11	7/16-20
			207102.3	8	5/16	10	27	16	14	1/2-20
	350	350	207103.3	10	3/8	10	27,5	16	14	9/16-18
			207104.3	12	1/2	12	32	18	19	3/4-16
			207105.3	14-15-16	5/8	16	37	20	22	7/8-14
			207106.3	18-20	3/4	20	42	23	27	1 1/16-12
	290	290	207107.3	25	1	25	46	26	33	1 5/16-12
	240	240	207108.3	30-32	1 1/4	32	53	33	41	1 5/8-12
			207109.3	38	1 1/2	38	59	35	48	1 7/8-12
	350	350	207110.3	10	3/8	12	29,5	18	19	9/16-18
			207111.3	12	1/2	16	34	20	22	3/4-16
			207112.3	14-15-16	5/8	14	37	20	22	7/8-14
			207113.3	14-15-16	5/8	18	40	23	27	7/8-14
			207114.3	14-15-16	5/8	22	40	23	27	7/8-14
			207115.3	18-20	3/4	18	42	23	27	1 1/16-12
	290	290	207116.3	18-20	3/4	25	46	26	33	1 1/16-12
			207117.3	25	1	32	51	33	41	1 5/16-12
	240	240	207118.3	30-32	1 1/4	30	53	33	41	1 5/8-12
			207119.3	30-32	1 1/4	38	56	35	48	1 5/8-12

Notes: If you wish to order a fitting in stainless steel, please change the first two digit from 20.... to 21.... .
Articles available on request only.

BULKHEAD BARREL TEE

Type: 2072...3

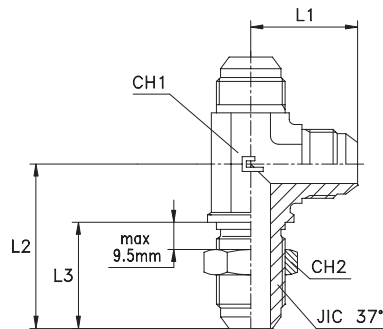

Series JIC	20.... [bar]	21.... [bar]	Ordering Complete	Ø Tube M	Ø Tube W	L1	L2	L3	CH1	CH2	JIC 37°
UNIVERSAL	450	450	207201.3	6	1/4	24,5	40,5	28,3	11	17	7/16-20
			207202.3	8	5/16	27	43,5	28,3	14	19	1/2-20
	350	350	207203.3	10	3/8	27,5	46	30,1	14	22	9/16-18
			207204.3	12	1/2	34,5	53,5	35	19	24	3/4-16
			207205.3	14-15-16	5/8	39,5	60,5	38,5	22	30	7/8-14
			207206.3	18-20	3/4	45	68	42,8	27	36	1 1/16-12
	290	290	207207.3	25	1	49,5	71	42,8	33	41	1 5/16-12
	240	240	207208.3	30-32	1 1/4	55	79	44,1	41	50	1 5/8-12
			207209.3	38	1 1/2	59,5	87	44,3	48	55	1 7/8-12

Notes: If you wish to order a fitting in stainless steel, please change the first two digit from 20.... to 21.... .
Articles available on request only.